

**THERMORON® AND  
POLYTETRAFLON® HEAT EXCHANGERS**  
PFA - ECTFE - PVDF - PP - PE



PLASTICS WITH  
UNLIMITED POSSIBILITIES  
MADE IN GERMANY

**POLYTETRA**



## THERMORON® AND POLYTETRAFLON® HEAT EXCHANGERS



We have been dealing with plastics - especially fluoroplastics - for almost 30 years. Experience, creativity, meticulous work and our advisory services have allowed us to become a competent partner of industry.

We are offering you not only a complete range of fabrication and delivery in a difficult and extensive area but also comprehensive advice which shall help you to optimally use these plastics for solving varied applications and problems. Please ask us and profit from our longstanding experience in this sector.

### ► Products and industries

Thermoron® and Polytetraflon® heat exchangers are being successfully used in many industries. Starting with the galvanizing industry, the uses range from the chemical industry, the wastewater industry, the foodstuffs industry and the textile industry - as well as applications in environmental protection like for example desulphurization of flue gases - to the semi-conductor industry and the photovoltaic industry.

### ► Materials and production

The PFA, ECTFE, PTFE and PVDF fluoroplastics are utilized as materials. These fluoroplastics excel in a resistance to chemicals which is very good or even universal, as well as high resistance to temperatures and very good non-stick properties. If the chemicals being used and the operating temperatures allow it, then some configurations or structural shapes can also be manufactured from the PP und PE polyolefines. The production takes place with specially developed tools, or with welding machines that are monitored by computer for jig welding.



### ► Construction

The following main groups of heat exchangers can be differentiated:

- Shell and tube heat exchangers
- Suspended or plug-in heat exchangers
- Multiple heat exchangers
- Modular heat exchangers
- Round heat exchangers
- Mini-heat exchangers

Each of these configurations or structural shapes has its special advantages, so that they are designed and offered for specific uses. The hose geometries can also be adapted to the special pressure ratios, in addition to the configurations or structural shapes. Furthermore, individually developed configurations or structural shapes are realizable for special applications.

### ► Design and documentation

The heat exchangers are designed with the aid of computers (CAD) on the basis of information from the specific customer. The customer receives all of the necessary information about the connecting pipework and the processing design, in addition to the heat calculations and CAD drawings. Extra components like for example connecting pipework, strainers and pressure-control valves are offered.

All results from the pressure tests and confirmations of the computer-aided welding parameters, as well as the relevant documents about operating the heat exchangers, are available.

► You can find extra details about the constructions, online questionnaires and online design aids on the internet at

[www.polytetra.com](http://www.polytetra.com)

Do you have any questions?  
Advice : + 49 (0)2166 / 95 90 – 0  
Email: [heatexchanger@polytetra.com](mailto:heatexchanger@polytetra.com)

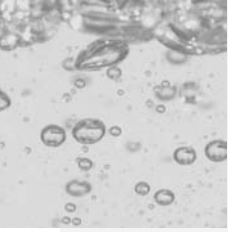

## POLYTETRAFLON® SHELL AND TUBE HEAT EXCHANGERS

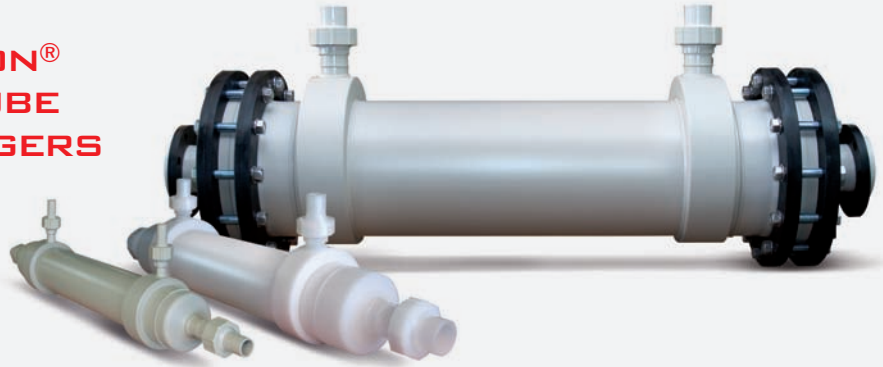

Shell and tube heat exchangers consist of an external shell tube and internal multiple hoses which consist of a large number of hoses of small nominal diameter. The internal hoses are welded in two perforated bases, which are then welded to the external shell tube. The first medium flows through the external shell tube and the second medium flows through inside the hoses. The hotter medium is cooled down and the cooler medium is heated up in this operation.

The number of external and internal passages can vary while doing so, according to the application. The media are mainly conducted in the counterflow or cross-counterflow, in order to achieve an optimum transfer of heat.

The Polytetraflon® shell and tube heat exchangers are manufactured completely from the PFA, ECTFE and PVDF fluoroplastics as well as the PP polyolefine. Possible contamination by other materials is prevented because of that.

All of the welded connections for conducting the media internally are manufactured in the contactless IR butt-welding process: this is particularly important when using

pure media and the purest media because this welding process avoids dead spaces which can lead to bacterial contamination for example. All of the IR welds are computer-aided and the welding parameters of all the connections are documented. In addition, all heat exchangers are pressure-tested internally and externally.

### ► Configurations and structural shapes

The Polytetraflon® shell and tube heat exchangers are manufactured with an internal passage and an external passage as standard. They are fabricated by being completely jig-welded in the sealed configuration or structural shape. Configurations or structural shapes that are openable on one side or both sides can be realized by the utilization of fixed or loose flanged connections. The utilization of changeable multiple tubes is also possible in this case.

### ► Lateral connecting ring

As a result, the external medium is not conducted in the internal hoses directly but guided and conducted through a lateral connecting ring on the side around the sheathing tube. The mechanical loading is reduced on the hoses because of that and the service life is increased.

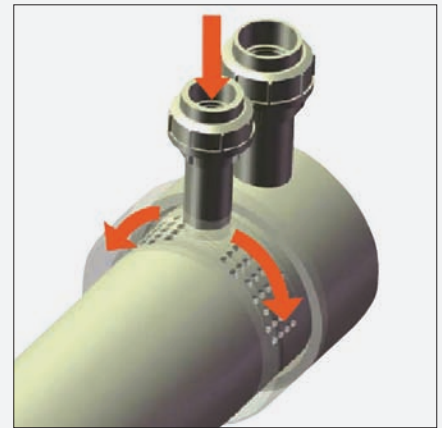

*Deviation of the lateral connecting ring.*

### ► Connections

The position and the type of lateral connections can be designed for the specific customer. The connections for the internal passage of media can be fitted straight or laterally outgoing with connections which are designed for the specific customer.

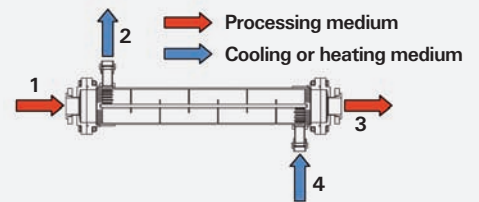

Material	Maximum nominal diameter in mm	Maximum length in mm	Maximum exchange surfaces in sq.m.
PFA	DN 100	3000 mm	7 sq.m.
ECTFE	DN 150	5000 mm	35 sq.m.
PVDF	DN 280	5000 mm	107 sq.m.
PP	DN 280	5000 mm	92 sq.m.

► You can find extra details about the constructions, online questionnaires and online design aids on the internet at

[www.polytetra.com](http://www.polytetra.com)

Do you have any questions? Advice : + 49 (0)2166 / 95 90 – 0  
Email: [heatexchanger@polytetra.com](mailto:heatexchanger@polytetra.com)

## POLYTETRAFLON® SUSPENDED AND PLUG-IN HEAT EXCHANGERS

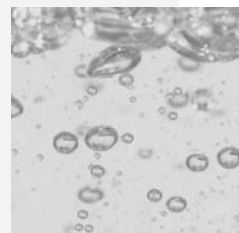

These multiple heat exchangers are a special form of the shell and tube heat exchanger. The external shell tube is utilized as a perforated protective tube in this case or it can be omitted completely. The medium is conducted in two passages through the hoses; the deviation takes place in one of the end caps which is designed as a floating head.

The heat exchangers are particularly suitable for vertical or horizontal installation in containers, whenever the space available is limited. The fastening can take place for the specific application on manholes or appropriate tubular supports by means of flanged connections, screwed connections or jig-welded connections.

The suspended and plug-in heat exchangers are completely manufactured from PFA, ECTFE, PVDF or PP. Exchange surfaces and dimensions are designed for the specific customer, as are the type and position of the screwed connections too.

▶ You can find extra details about the constructions, online questionnaires and online design aids on the internet at  
[www.polytetra.com](http://www.polytetra.com)

Do you have any questions?  
Advice : + 49 (0)2166 / 95 90 – 0  
Email: [heatexchanger@polytetra.com](mailto:heatexchanger@polytetra.com)



## POLYTETRAFLON® MULTIPLE-SURFACE HEAT EXCHANGERS

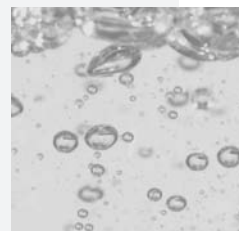

This version of the multiple heat exchanger is particularly suitable for small baths or whenever the space available is limited. High outputs in the smallest space can be realized, on account of the good ratio between the exchange surface and space required in connection with a thin-walled hose.

They can be designed in a U shape with one passage or in a square shape with several passages. The heat exchangers can be installed not only in the floor construction but also in the wall construction. The connecting pipework and type of connections are designed for the specific customer. The dimensions can be designed for the specific customer. The multiple-

surface heat exchangers are manufactured from the PFA, ECTFE, PVDF and PP materials. Reinforcing frames are fabricated from PTFE for the special shapes made from PFA.

▶ You can find extra details about the constructions, online questionnaires and online design aids on the internet at  
[www.polytetra.com](http://www.polytetra.com)

Do you have any questions?  
Advice : + 49 (0)2166 / 95 90 – 0  
Email: [heatexchanger@polytetra.com](mailto:heatexchanger@polytetra.com)

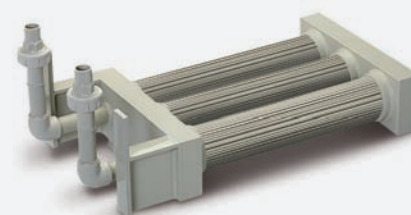
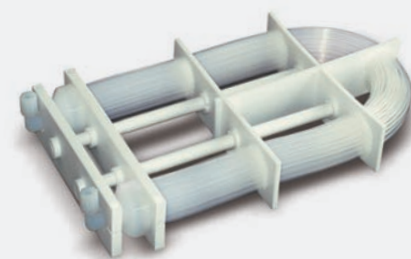

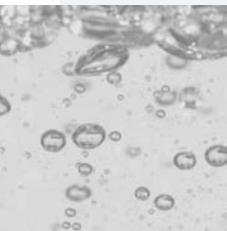

## Thermoron® MODULAR HEAT EXCHANGERS

Thermoron® modular heat exchangers are used for the cooling or heating of aggressive liquids in containers. They are completely manufactured from the PVDF, PP and PE materials: whereby a further area of use is covered regarding resistance to chemicals and temperatures.

These heat exchangers are manufactured from individual hose modules and standardized components. The hose modules consist of hose spirals, which are inserted into rails and jig-welded with specially developed hose connections to specially constructed welding and assembling devices. These hose modules are then fitted to a rigid frame, into which the medium's supply and discharge pipelines are integrated. The modular rails are screwed to the frame and the hose connections are welded into the frame's parts which conduct the media. The most varied dimensions and exchange surfaces are thus realizable in a compact and very rigid construction by means of the modular construction. The

standard modules are manufactured in four sizes and they can now be combined individually: as a result, exchange surfaces from 0.4 sq.m. to 45 sq.m. are allowed by up to three modules next to or over each other and up to ten layers.

The position and the type of holding devices and the connecting pipework can be designed for the specific customer. The heat exchanger can be provided for mounting on a wall or floor. Weights against floating and protective plates against mechanical damage in the process are possible as options.

Every single hose module as well as the complete heat exchanger is pressure-tested.

Special configurations or structural shapes of other geometries are possible on enquiry.

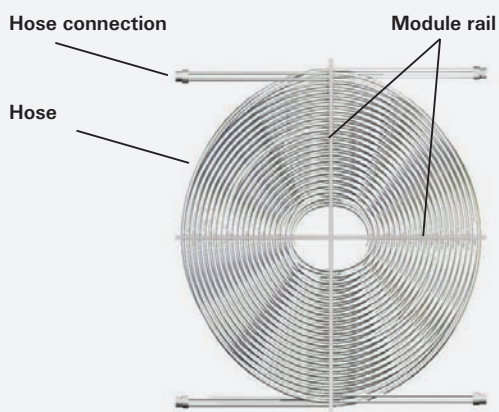

▶ You can find extra details about the constructions, online questionnaires and online design aids on the internet at

[www.polytetra.com](http://www.polytetra.com)

Do you have any questions?  
Advice : + 49 (0)2166 / 95 90 - 0  
Email: [heatexchanger@polytetra.com](mailto:heatexchanger@polytetra.com)

## POLYTETRAFLON® FLOW HEATERS

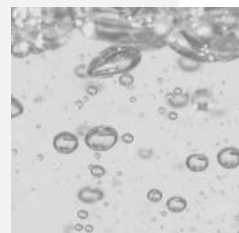

The flow heaters consist of Polytetraflon® heaters made from electrical tubular radiators encapsulated in PFA within a casing made from PVDF. A contactless level-monitoring device as well as a PT 100 temperature sensor are provided as standard. The heating elements can be optionally equipped with a thermocontrol as protection against overheating.

The flow heaters have a heating output up to 18 kW and they are utilized for the electric heating of chemical media in the semiconductor industry for example. The heaters can be equipped with different, specific surface loadings of 0.5 W/cm<sup>2</sup>, 1.0 W/cm<sup>2</sup>, 1.5 W/cm<sup>2</sup> and 2.2 W/cm<sup>2</sup> according to the medium. Voltages of 230 V and 400 V are standard; special voltages are possible on enquiry.

The PFA heating elements are exchangeable individually. The casing is completely made from PVDF. The screwed connections can be equipped for the specific customer.

Configurations or structural shapes in which all of the components carrying media are completely made from PFA, as well as specific heating outputs, are possible on enquiry.

▶ You can find extra details about the constructions, online questionnaires and online design aids on the internet at

[www.polytetra.com](http://www.polytetra.com)

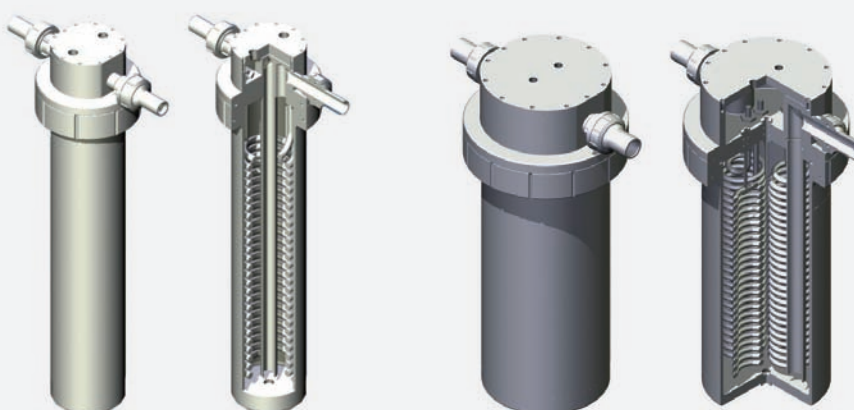

## SPECIAL CONFIGURATIONS AND STRUCTURAL SHAPES

Examples of heat exchangers made from different materials for specific customers.

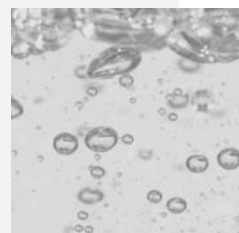

Square heat exchangers made from PFA hoses in PTFE or PVDF frames.



Standing multiple-surface heat exchangers.



Round heat exchangers in glass casings.



**DO YOU ALSO REQUIRE  
ELECTRIC HEATERS  
FOR HEATING UP  
AGGRESSIVE MEDIA?  
SPEAK TO US.**

POLYTETRA GmbH • Hocksteiner Weg 40 • D-41189 Mönchengladbach  
Telephone: + 49 (0)2166 / 95 90 - 0 • Fax: + 49 (0)2166 / 95 90 - 55  
E-Mail: [heatexchanger@polytetra.com](mailto:heatexchanger@polytetra.com) • Internet: [www.polytetra.com](http://www.polytetra.com)

**POLYTETRA**